

Components list

Name	Specification	Qty	Name	Specification	Qty
Breaker	DZ47-60	1pc	Current transformer	LH251554	1pc
EMI1	6laps	1pc	Resonant inductance	7 laps	1pc
3-ph bridge	60A/1200V	1pc	Main	26:4	1pc
IGBT	SKM100/BSM75	2pcs	900GConverter inductance	26 laps	1pc
Fan	200FZY8-S	1pc	800GDisplay board	PCB7 V1.3	1pc
Current sensor	JK500T33	1pc	500GDriver board	IGBT V2.2	1pc
LCD	LCM12864Z	1pc	800VVoltage using board	PCB4 V2.1	1pc
Main control board	DSP V2.4.1	1pc	900GFilter inductance	LJ500G03-30	1pc

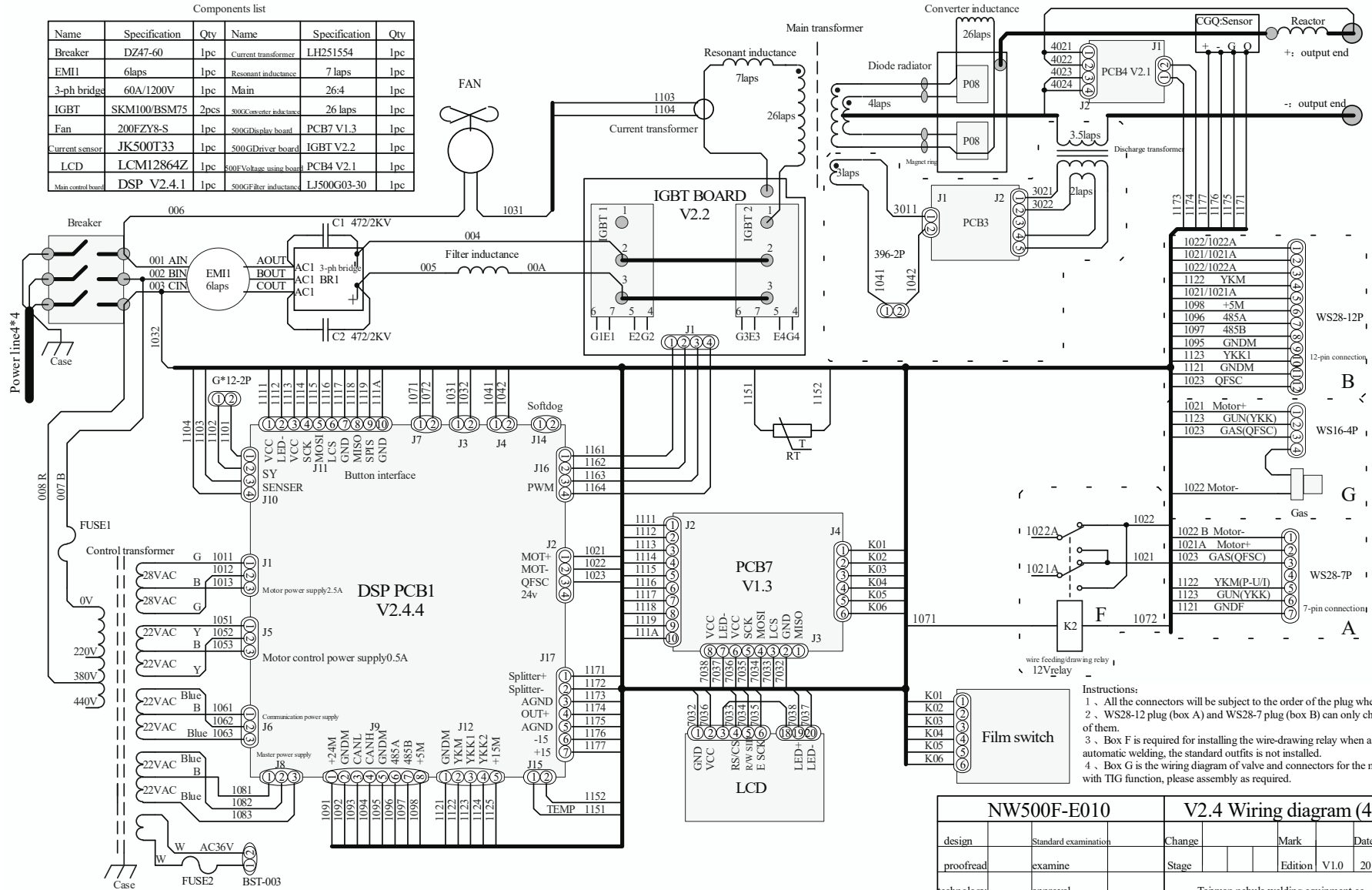

Instructions:  
 1. All the connectors will be subject to the order of the plug when wiring.  
 2. WS28-12 plug (box A) and WS28-7 plug (box B) can only choose one of them.  
 3. Box F is required for installing the wire-drawing relay when a robot or automatic welding, the standard outfits is not installed.  
 4. Box G is the wiring diagram of valve and connectors for the machine with TIG function, please assembly as required.

NW500F-E010		V2.4 Wiring diagram (4.12Pin)		
design	Standard examination	Change	Mark	Date
proofread	examine	Stage	Edition	V1.0 2013.11.26
technology	approval	Taiyuan nebula welding equipment co., LTD		
Issue number:		Date of issue:		