







SELEÇÃO DE CONSUMÍVEIS PARA CORTE MANUAL/AUTOMATIZADO/MECANIZADO SL60/100

SET OF CONSUMABLES FOR MANUAL/AUTOMATED CUTTING TORCH SL60/100

Foto/Photo	Pos.	Código/Code	Ref	Descrição/Description	Amp
	01	0700.6001	9-8215	Eletrodo de Corte Electrode	
	02	0700.6002	9-8213	Cartucho Cartridge	
	03	0700.6010	9-8205	Bico de Corte Arraste Tip	20 A
		0700.6011	9-8206		30 A
		0700.6012	9-8207		40 A
		0700.6013	9-8252		60 A
	04	0700.6003	9-8208	Bico de Corte Tip	40 A
	05	0700.6004	9-8209	Bico de Corte Tip	50-55A
		0700.6005	9-8210		60 A
	06	0700.6006	9-8231	Bico de Corte Tip	70 A
		0700.6007	9-8211		80 A
		0700.6008	9-8212		90/100A
		0700.6009	9-8253		120 A
	07	0700.6014	9-8225A	Bico de Corte de Goivagem Gouging Tip	40 A
		0700.6015	9-8226B		50-100 A
		0700.6016	9-8227C		60-120 A
		0700.6017	9-8228D		60-120 A

Foto/Photo	Pos.	Código/Code	Ref	Descrição/Description	Amp
	08	0700.6026	9-8237	Corpo do Bocal de Retenção Shield Cup Body	
	09	0700.6025	9-8218	Bocal de Retenção Shield Cup	
	10	0700.6027	9-8243	Bocal Defletor Manual/ Automatizado Deflector Shield Cup	
	11	0700.6021	9-8245	Bocal Mecanizado Mechanized Nozzle	40 A
		0700.6023	9-8238		50-60 A
		0700.6024	9-8239		70-100 A
		0700.6047	9-8256		120 A
	16	0700.6018	9-8244	Bocal de Arraste Drag Shield Cup	40 A
		0700.6019	9-8235		50-60 A
		0700.6020	9-8236		70-100 A
	18	0700.6051	9-8258	Espaçador de Corte Standoff Cutting Guide	120 A
		0700.6038	9-8281		
	19	0700.6028	9-8241	Bocal de Goivagem Gouging Shield Cup	

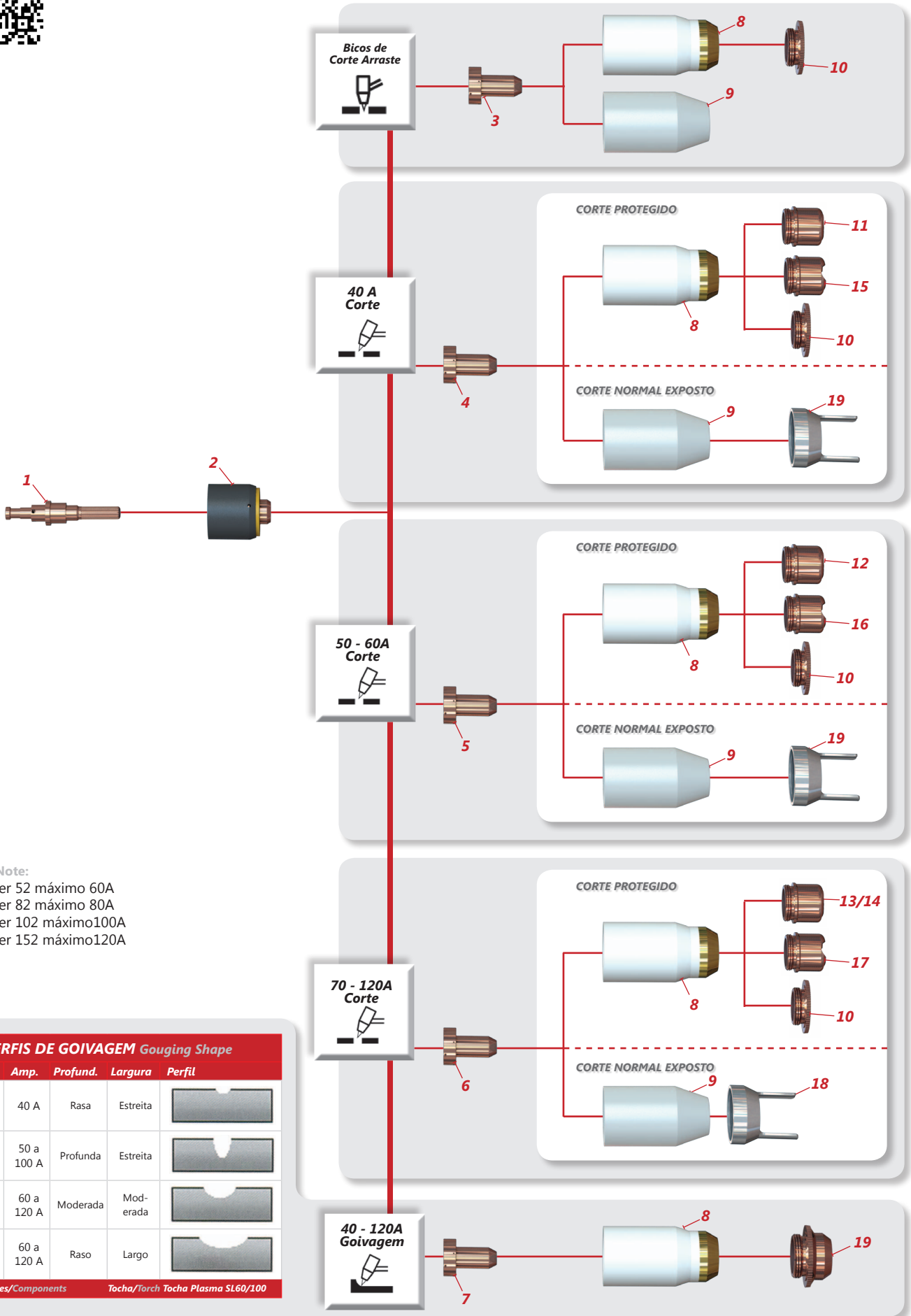

Nota:/Note:

Cutmaster 52 máximo 60A
Cutmaster 82 máximo 80A
Cutmaster 102 máximo 100A
Cutmaster 152 máximo 120A

PERFIS DE GOIVAGEM Gouging Shape

Código	Amp.	Profund.	Largura	Perfil
0700.6014 Ref. 9-8225A	40 A	Rasa	Estreita	
0700.6015 Ref. 9-8226B	50 a 100 A	Profunda	Estreita	
0700.6016 Ref. 9-8227C	60 a 120 A	Moderada	Mod- erada	
0700.6017 Ref. 9-8228D	60 a 120 A	Raso	Largo	

Componentes/Components Tocha/Torch Tocha Plasma SL60/100